

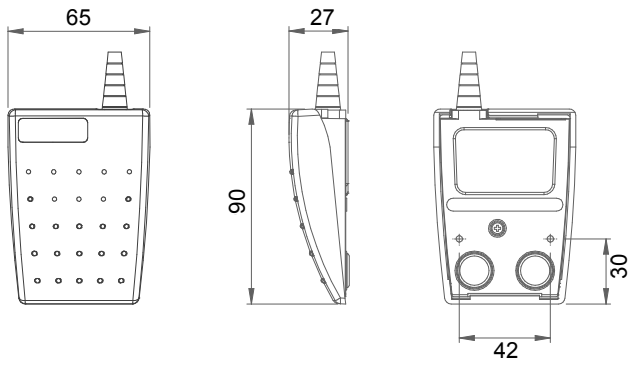

- ▶ **Low profile switch designed for improved user comfort**
- ▶ **All plastic construction with raised tread pattern, ideal for palm or foot operation**
- ▶ **Versatility and innovative design make it an ideal product for OEM use**
- ▶ **Switches designed to meet medical, industrial/office/commercial standards**
- ▶ **Option for customers to fit own cables**

Specifications	
Standards/approvals	UL File No: E353500 • EN 60601-1:2007/A2:2021 • IEC 60601-1:2005+AMD1:2012+AMD2:2020 • CAN/CSA C22.2. No 60601-1:08 • CAN/CSA C22.2. No 60601-1-14/A1+A2:2022 • ANSI/AAMI ES60601-1:2005/A1:2012 +A2:2021
Degree of protection	EN 60529 IPX2
Connection method	Stripped cable cores or connector of your choice
Electrical rating	See table page 2
Contact configuration	SPST N/O, SPST N/C, SPCO
Operating temperature range	-5°C to +40°C
Body material	Thermoplastic
Weight	0.212Kg (including cable)
Additional information	Customized versions available (logos, cordsets, colours, guards)

Dimensions



# 6223 LEPTRON PALM/ FOOTSWITCH



## Ordering information

(Please use the characters in the chart below to create your product code)

**Sample Code**                    6223 - A A A B - ZAZA - A 00

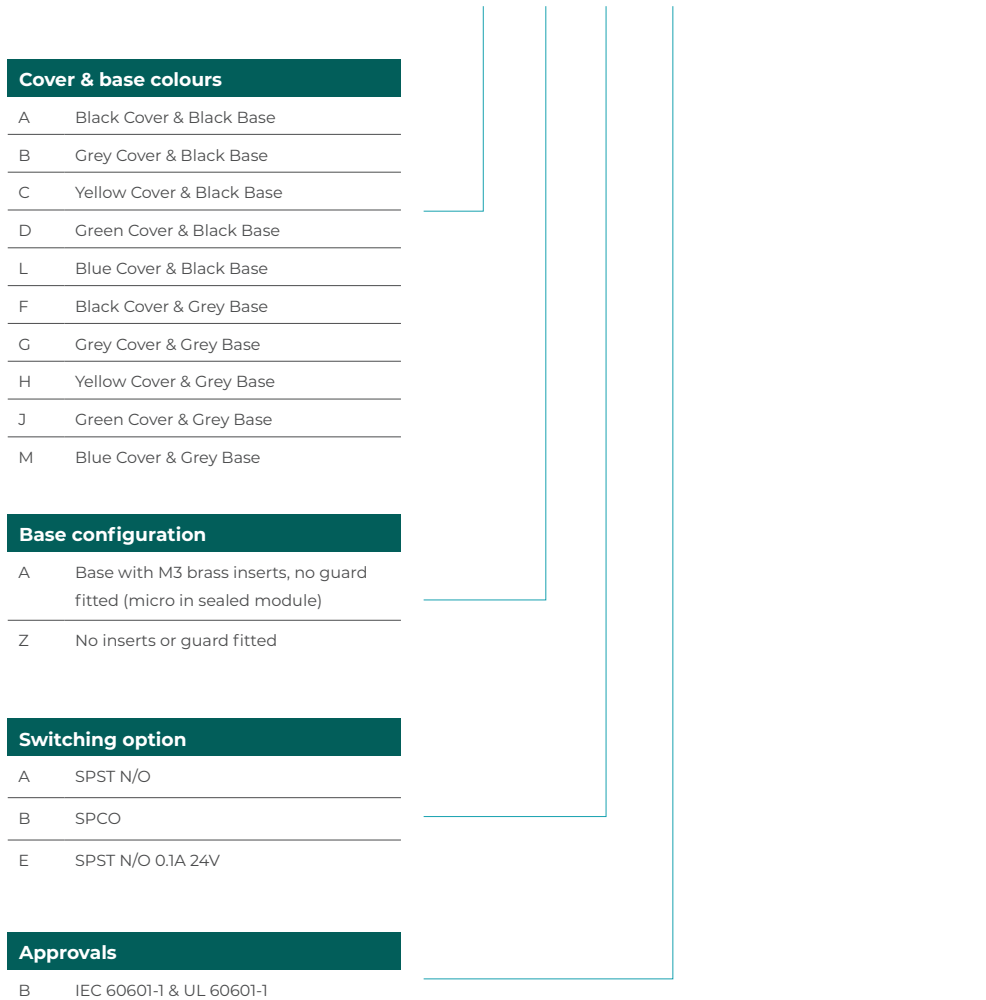

If you require a customized solution for your program contact our sales team.

# 6223 LEPTRON PALM/ FOOTSWITCH



## Ordering information

(Please use the characters in the chart below to create your product code)

**Sample Code**                    6223 - A A A B - ZAZA - A 00

### IEC 60601-1 & UL 60601-1, 2 & 3-core cordsets

AZAZ	2-core grey 1.75A 24V
BZBZ	2-core grey 0.1A 24V
CZCZ	2-core black 1.75A 24V
DZDZ	2-core black 0.1A 24V
EZEZ	2-core grey screened, 1.75A 24V
FZFF	2-core grey screened, 0.1A 24V
ZAZA	3-core grey 1.75A 24V
ZBZB	3-core grey 0.1A 24V
ZCZC	3-core black 1.75A 24V
ZDZD	3-core black 0.1A 24V
ZEZE	3-core grey screened, 1.75A 24V
ZFFF	3-core grey screened, 0.1A 24V
ZZZZ	No option chosen

### Non cable variants, customer fitted cables, IPX2 components

A	Microswitch fitted, SPCO 16A 24V, 6.3mm x 0.8mm push-on tag
B	Microswitch fitted, SPCO 16A 24V, 6.3mm x 0.8mm solder tag
E	Microswitch fitted, SPCO 0.1A 24V, 6.3mm x 0.8mm solder tag
Z	No option chosen

### Special attributes

- Customer specified/supplied cordset for factory fitting with/out plug
- Customer specified identification & label combination - the suitability may not be covered by UL Guard fitted
- Cable length variation if different from 2m
- Z No option provided

If you require a customized solution for your program contact our sales team.